

**PRINCIPAL LED**

WE SPEAK YOUR LANGUAGE

P-LED.com  
(325) 227.4577

## INSTALLATION GUIDE

# STREET WRAP GEN 2



## CONTENTS

- Page 2** Mounting Bracket Layout  
**Page 3** Installing Street Wrap into Mounting Brackets  
**Page 4** How to Wire RGB  
**Page 5** Custom Cut to Fit End of Runs & Corners  
**Page 6** Corner Mounting Options  
**Page 7** Mounting on Incline or Vertically  
**Page 8** Connecting Transformers

## COMPONENT IDENTIFICATION & REQUIRED TOOLS

### MATERIALS

Aluminum Extrusion  
 Lens (Acrylic)  
 Mounting Clip  
 Profile Dimensions w/ Mounting Clips  
 Acrylic, UV and impact resistant  
 Aluminum  
 Street Wrap 1.25"W x 96"L x 2.1875"H

### REQUIRED TOOLS

- 25' Measuring Tape
- 100' Measuring Tape Framing Square
- Square -1'
- Phillips Screwdriver
- Portable Rechargable Drill
- -5/16" hexbit and unibit
- -Masonry bits (If brick wall)
- Extension Cord
- Phillips Screwdriver
- Sawzall or Compound Saw
- Carpenter Pencil
- Caulk Gun
- Box Knife
- Wire Strippers
- Wire Snips
- Laser Tool or Chalk Line Substitute
- Fasteners for the Application if Applicable

24V IP67 LED Strip comes pre-installed.

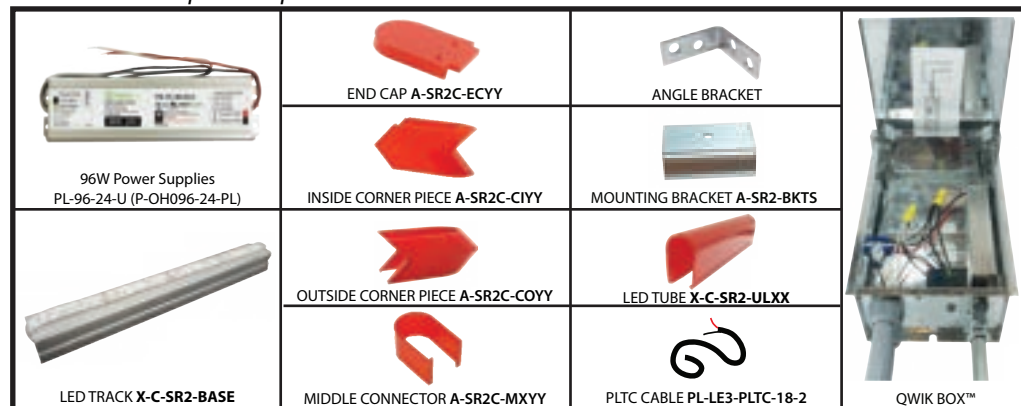

YY = Blue (BL), Green (GR), Red (RD), White (WH)

## GETTING STARTED

Following these few simple steps will ensure a successful installation each time.

Read all instructions before starting installation.

1. Inspect the boxes for damage and check the parts against the supplied parts list.  
*Note: Report damaged parts or shortages immediately to prevent job slowdown/stoppage to place of purchase.*
2. Refer to the Build-A-Border document provided on our website at [P-LED.com/street-wrap-gen-2](http://P-LED.com/street-wrap-gen-2) and confirm job measurements.
3. Lay out your job on paper, making note of Power Supply placement. Power Supplies can be placed at the end of runs or side by side to power allowable linear footage in each direction.

*Note: If job measurements do not correspond to provided drawing, call Principal LED immediately at (325) 227-4577. Remember: No more than four (4) 96" units per 96W Power Supply.*

## 24VDC LED STRIP SPECS

Color	W/Ft.	W/Unit
Pure White	2.75	22
Red	2.75	22
Blue	2.75	22
Green	2.75	22
*RGB	2.75	22

## ELECTRICAL

Input	100-277VAC
Output	24VDC
Maximum Load	96W
Current at Max. Load	4A



## STREET WRAP GEN 2™ MOUNTING BRACKET LAYOUT

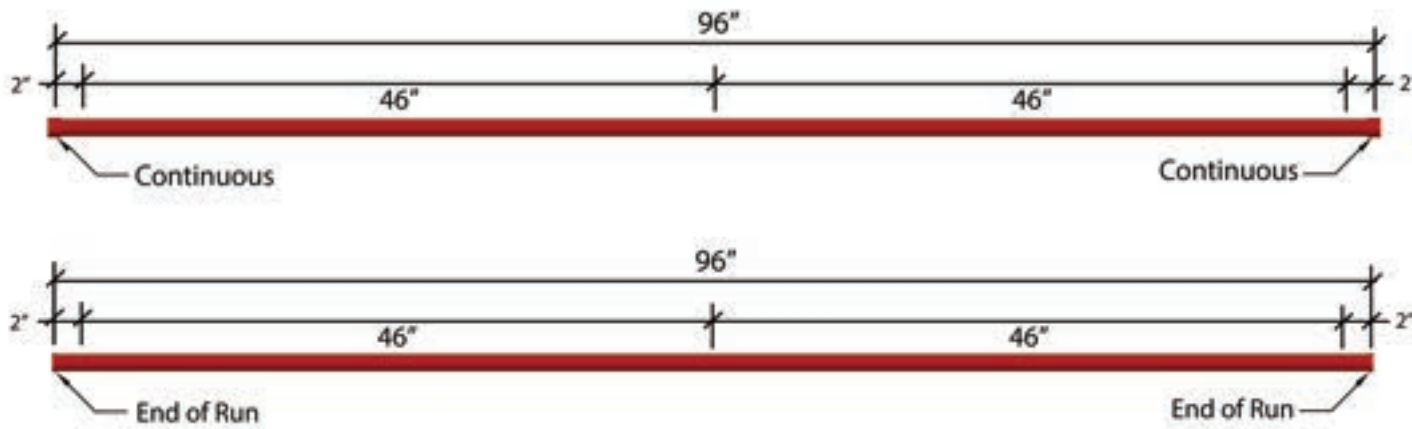

1. Use a chalk line, gauge, laser level, or other means to be certain the run is straight, marking locations for brackets.
2. Install three (3), evenly spaced, mounting brackets per section. Ensure there are at least two inches between the end of the track and the mounting bracket as shown in the picture above.
3. Use a 0.125" drill bit to add a drain hole in lens in the center of the run. Never drill drain hole when installed on the LED base.

**Note:** There must be a 0.1875" space left between each section when using middle or corner connectors.

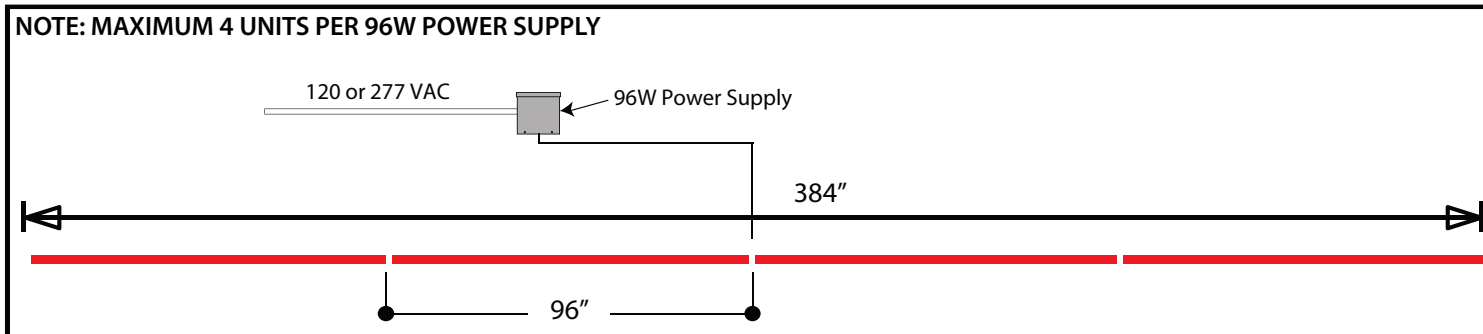

## INSTALLING STREET WRAP GEN 2™ INTO MOUNTING BRACKETS

1. Connect wires from one section to another using red butt splice wire connectors, silicone filled wire nuts or TE connectors. No more than two (2) 96" units in a series.
2. Lay the section being added on the mounting brackets. After making wire connections, tuck the wires and connectors BEHIND the base track. Caulk notch.
3. Place track with LEDs, but no lens, over mounting brackets and press firmly, until securely snapped in place.
4. Bring Street Wrap™ sections close together by pushing sections together, leave a 0.1875" approximate expansion gap between track sections.
5. Install Lens on LED base.
6. Install an End Cap at the beginning and end of runs with silicone.
7. Finish by clipping a middle connector over both sections. Use a small amount of silicone.

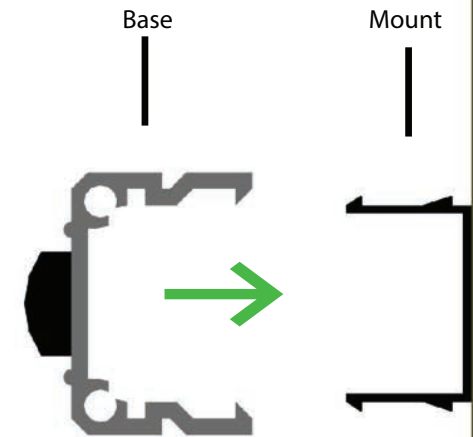

Push LED base onto mounting bracket.

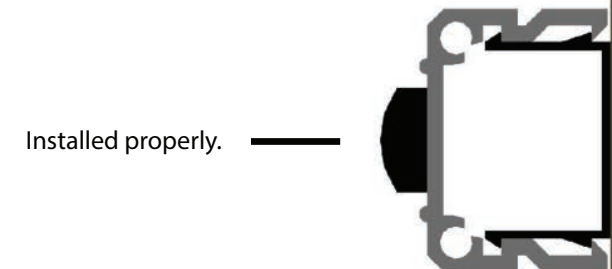

# HOW TO WIRE RGB STREET WRAP GEN 2™

## POWER AMPLIFIER FIGURE

Also see RGB Controller spec sheet for more information on wiring.

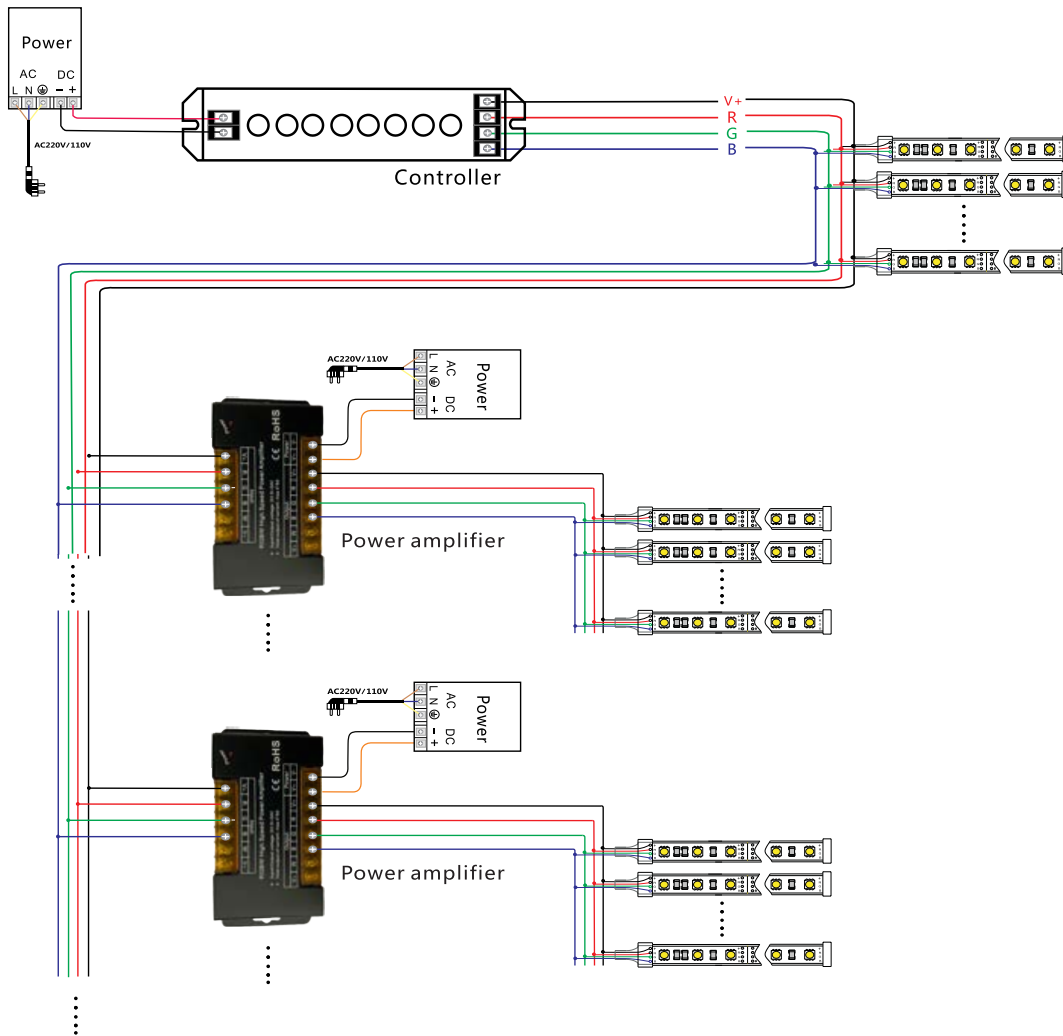

## CUSTOM CUT TO FIT END OF RUNS & CORNERS

### END OF A RUN

1. Peel back IP67 LED Strip before cutting track.
2. Measure, mark and cut lens and track to required length. Use a fine blade.
3. Add drain holes in the center of the cut piece of lens before reinstalling the lens to the base.
4. Reinstall IP67 LED Strip to desired length ensuring to silicone down the tape and using silicone to seal cuts made to IP67 LED Strip.

**NOTE: Always test-light the Street Wrap Gen 2™ after making field cuts. Never connect AC voltage lines to LEDs on the Street Wrap Gen 2™.**



### VERY IMPORTANT

Insulate or remove unused wires at the end of run to prevent shorting. Do not connect wires together or to next circuit.

### NOTE

Factory miter cuts will affect the overall length of each 8 foot section of Street Wrap Gen 2.

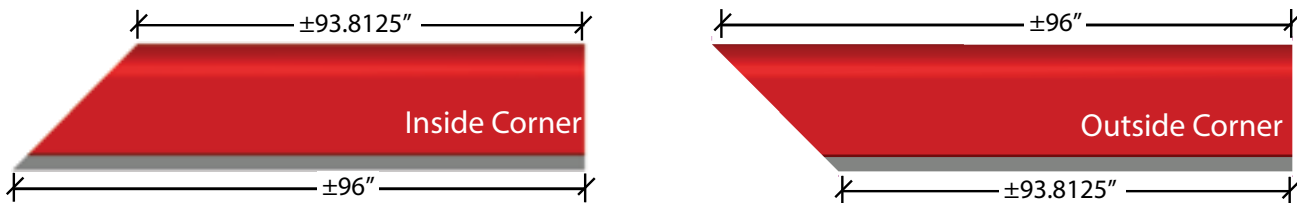

## CORNER MOUNTING OPTIONS

OPTION 1

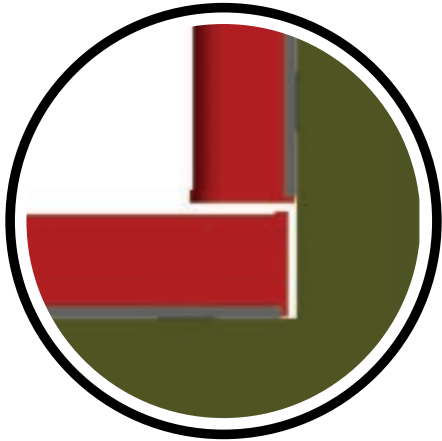

INSIDE BUTT JOINT



INSIDE BUTT JOINT CORNER

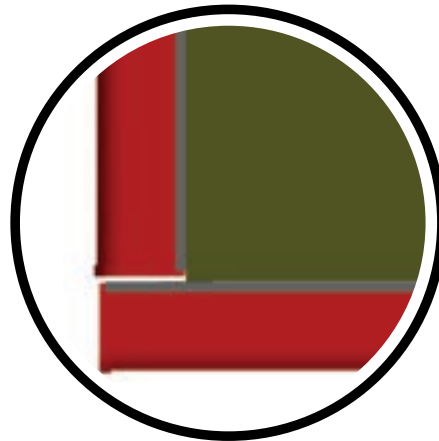

OUTSIDE BUTT JOINT CORNER

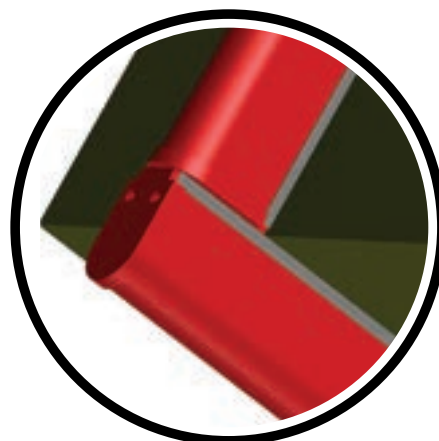

OUTSIDE BUTT JOINT

OPTION 2



INSIDE MITER CUT CORNER



OUTSIDE MITER CUT CORNERS

## MOUNTING STREET WRAP GEN 2™ ON INCLINE OR VERTICALLY

When mounting Street Wrap Gen 2™ on an incline or vertically, two things must be prevented. First the Street Wrap Gen 2™ must be kept from sliding down, while still allowing for expansion/contraction with temperature changes. Second, water must be sealed out with silicone since it will run down the top of the Street Wrap Gen 2™. Seal the middle connectors to the upper Street Wrap Gen 2™ to keep water from penetrating.

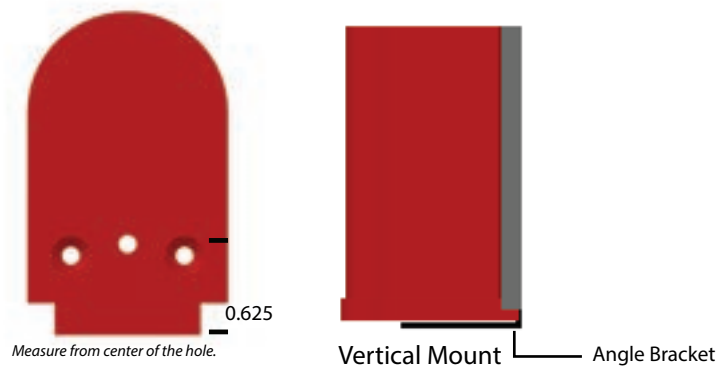

Drill one (1) hole in the end cap on the bottom end of the run to allow water to escape.



## CONNECTING TRANSFORMERS

*Note: Stop and make sure the supplied power supply is 277VAC rated with any primary voltage greater than 120.*

1. Attach Qwik Boxes to available support member. See Qwik Box install guide.
2. Connect power supplies to primary wiring.
3. Install strain relief for low voltage wire.
4. Drill 1/2" hole through the fascia. A conduit fitting can be installed so that conduit can be used.
5. Insert low voltage wire into the hole and connect to LED. Fill hole with silicone sealant.

*Note: Four 96" Street Wrap™ Border per 96W Power Supply.*

Side by side mounting location shown below can reduce primary and secondary wiring labor time.

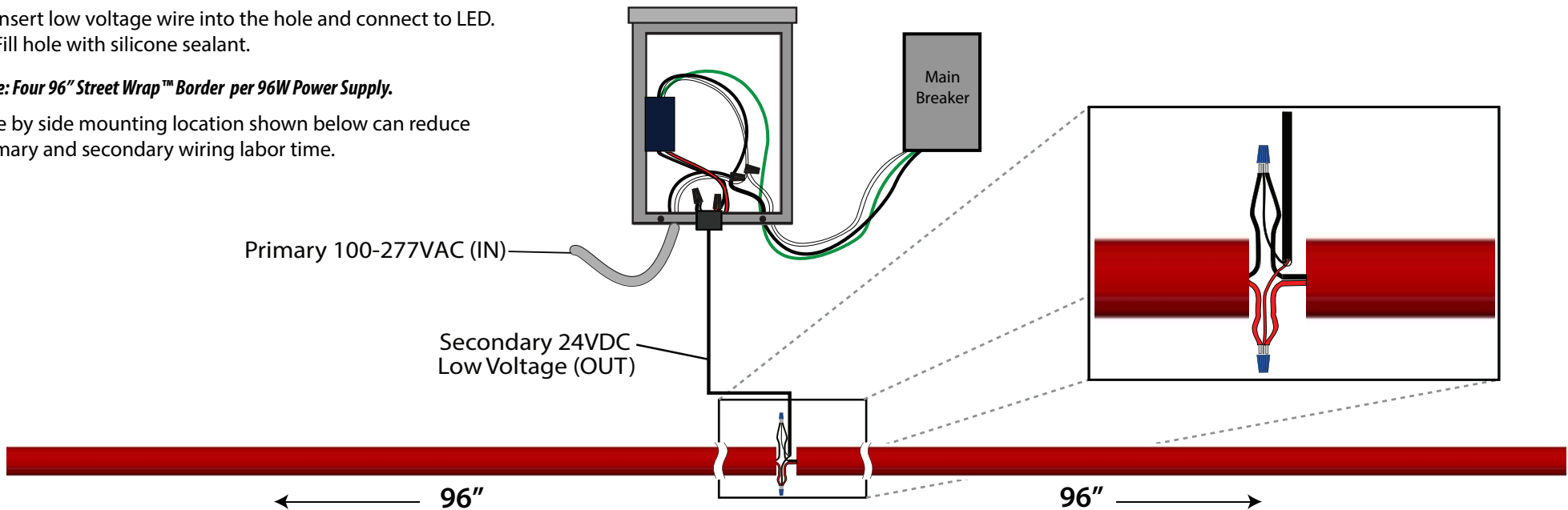
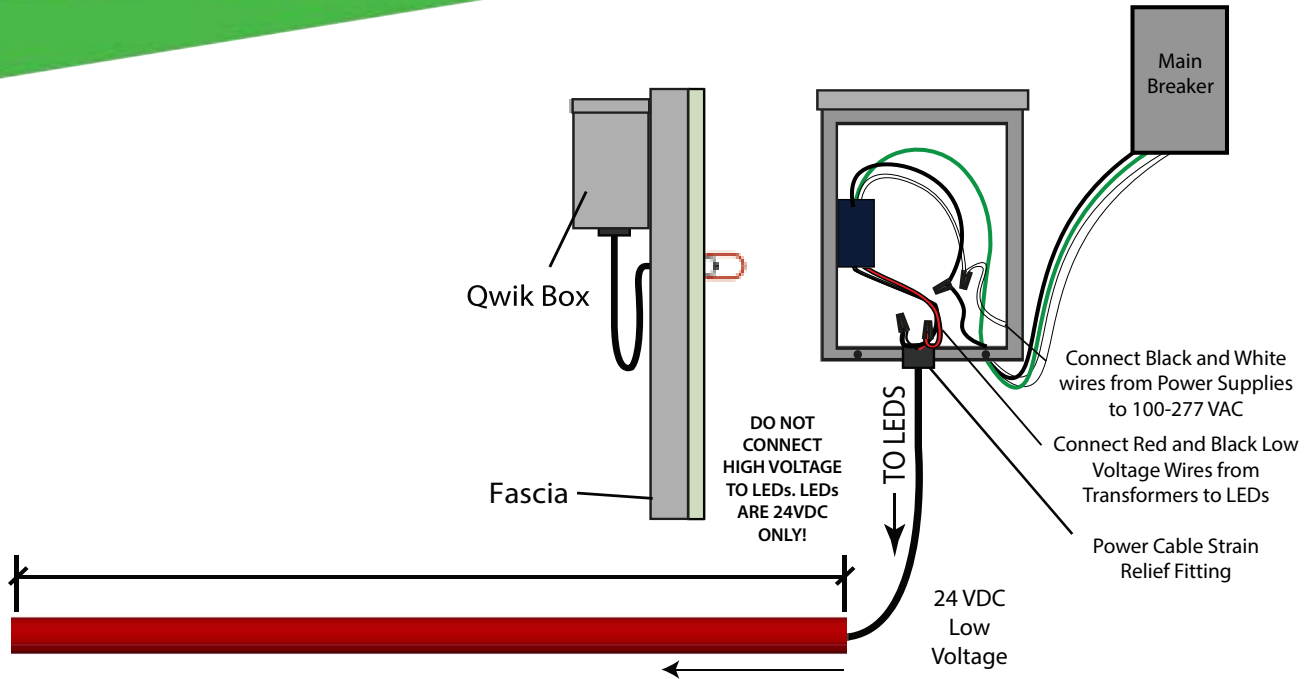

**VERY IMPORTANT:** KEEP LOW VOLTAGE CIRCUITS ELECTRICALLY SEPARATE, DO NOT CONNECT TRANSFORMERS OR LEDs FROM DIFFERENT 96" STREET WRAP GEN 2™ TOGETHER OR CONNECT MORE THAN FOUR 96" STREET WRAP GEN 2™ TO A 96W POWER SUPPLY!



 [www.p-led.com](http://www.p-led.com)

 (325) 227-4577

 3490 Venture Drive, San Angelo, Texas 76905

 [info@p-led.com](mailto:info@p-led.com)

